

ADDENDA

ADDENDUM NO. 02

DATE: June 15, 2021

PROJECT: WEST CAMERON AVENUE WATER MAIN REPLACEMENT – PHASE 2

OWASA CIP NUMBER: 275-52

OWNER: ORANGE WATER AND SEWER AUTHORITY

ENGINEER: McKim & Creed, Inc.

TO: Prospective Bidders

This Addendum forms a part of the Contract Documents and modifies the Bidding Documents dated May 2021, with amendments and additions noted herein below.

Acknowledge receipt of this Addendum in the space provided in the Bid form. Failure to do so may disqualify the Bidder.

This Addendum consists of 46 pages.

CHANGES TO THE SPECIFICATIONS:

1. Add the attached NCDWI Plans and Specifications Funding Approval to Appendix B; this document was not included in the Issued for Bid specifications.
2. Replace Section 00 41 44 – Proposal (Unit Price Contract – Bid Form) in its entirety with the enclosed Section 00 41 44 – Proposal (Unit Price Contract – Bid Form) (Addendum No.2)

CHANGES TO THE DRAWINGS:

1. As a clarification to Sheet C3, the existing 6-inch water line in S. Roberson Street is constructed of ductile iron pipe.
2. Delete Note 5 “All pavement shall be repaired within the same week it is cut” of Detail MC-03 on Sheet D4. As a clarification, see questions and responses below related to requirements for driving surfaces at the end of each workday.
3. Delete Detail MC-01 on Sheet D4 and replace it with the attached Detail MC-01 (Addendum No. 2).

RESPONSES TO BIDDER QUESTIONS:

Bidder Question 1: General Notes, Note #2 [Sheet G2]. This note does not provide a clear basis for bidding. As a contractor how are we to apply cost to unforeseen utilities or conditions that will not be found until additional locating or excavation. We feel this note should either be removed, or an allowance be provided to compensate for this note.

Engineer Response to Bidder Question 1: General Note 2 on Sheet G2 states that the Contractor shall be responsible for locating all utilities prior to construction and that the owner will work with the Contractor to revise the alignment or profile where possible if necessary. The

next to last sentence in General Note 2 on Sheet G2 is hereby revised to read, "Contractor shall locate existing utilities as required for new work." Should the Contractor encounter unforeseen utilities or differing site conditions that require out of scope work and/or relocation of existing utilities not included in the contract documents, the Contractor is to notify the Engineer in accordance with the conditions of the contract. The Contractor may be eligible for additional compensation for work outside of the original scope, in accordance with the conditions of the contract.

Bidder Question 2: Who will be providing the law enforcement, to assist with traffic control?

Engineer Response to Bidder Question 2: The Contractor will be responsible for coordinating and securing law enforcement to assist with traffic control through the local authority having jurisdiction (i.e., Town of Chapel Hill or Town of Carrboro). Refer to Sheets TMP-4, TMP-6, TMP-8, TMP-12, and TMP-13 for work zones denoting use of law enforcement during construction. All costs associated with securing law enforcement for assistance with traffic control as shown on the drawings are to be included in the lump sum bid item for traffic control.

Bidder Question 3: Confirm that traffic control devices shall be removed each day, and that normal traffic patterns are to resume until next workday.

Engineer Response to Bidder Question 3: The Contractor will be responsible for removing traffic control devices at the end of each workday to allow traffic to return to normal traffic patterns outside of allowable hours of construction, except where specifically listed otherwise on the plans. Refer to Phase III – Step B staging notes on Sheet TMP-3B for conditions requiring traffic control be left in-place outside of allowable hours of construction. Refer to all General Notes on Sheet TMP-2 for lane closure requirements and instructions regarding covering or removing traffic control signage when not in use. Refer to Staging Notes on Sheets TMP-3A and TMP-3B regarding asphalt restoration requirements at the end of each workday allowing traffic to return to normal traffic operations.

Bidder Question 4: Does asphalt have to be fully restored, surface coarse installed, prior to moving to next phase, or can asphalt be left 2" low?

Engineer Response to Bidder Question 4: At the end of each workday, all pavement cuts shall be repaired with temporary asphalt patch, permanent asphalt patch or steel road plates. Temporary asphalt patch is to consist of a minimum of 1.5-inches of hot mix asphalt over compacted subgrade. Use of aggregate base course (ABC) and cold patch asphalt are not acceptable for temporary driving surfaces. If steel road plates are used at any location, they are to be installed per the requirements of the NCDOT Encroachment agreement. Refer to Details MC-01, MC-02, and MC-03 on Sheet D4 for permanent asphalt repair requirements for local authorities having jurisdiction. Refer to Pavement Edge Drop Off Requirements as listed on Sheet TMP-2 for additional temporary paving restoration requirements. All edge drop offs are to be repaired in the same week they are cut and in advance of all weekends and holidays. There will be no separate payment for the use of temporary asphalt or steel road plates. Payment for asphalt restoration will only be made for permanent asphalt patch as listed in the bid form and installed per the requirements listed in the Contract Documents.

Bidder Question 5: How are temporary services to be abandoned?

Engineer Response to Bidder Question 5: Temporary services connected to AC water mains shall be abandoned or removed at the same time in which the connecting AC water main is abandoned. Temporary water services connected to water mains constructed of materials other than AC shall be abandoned per requirements listed in Specification 02510 – Water Distribution, Section 3.1, Part 7. All pipes greater than or equal to 4-inches in diameter, which are to be abandoned in-place, shall be grout filled in accordance with General Note 12 on Sheet G2. As listed in Specification 01026 – Unit and Lump Sum Prices, all costs associated with abandonment of temporary water services are to be included in the bid unit price for the temporary water service, with no separate payment being made for grout fill abandonment or removal of temporary water service lines.

Bidder Question 6: What should the typical profile be for each temporary service? Shall it cross under or over the 24" reclaim water line?

Engineer Response to Bidder Question 6: Minimum depth of cover for temporary water services shall be 24-inches. As a clarification, the existing 24-inch water transmission main is a potable water main and not a reclaim water main as listed in the question.

Bidder Question 7: Can temporary services be installed while initial phases of work are being tested?

Engineer Response to Bidder Question 7: Temporary water services can be installed during testing of other phases of work provided there is no disruption in water service to customers.

Bidder Question 8: Does both railroad crossing have to be performed during the same 2 week shutdown period? Or are they to be done during separate periods?

Engineer Response to Bidder Question 8: The railroad crossings along South Merritt Mill Road and West Cameron Avenue are to both be completed within the same two-week shutdown period. Refer to General Note 10 on Sheet G2 for timing and notification requirements for all work within the railroad right-of-way.

Bidder Question 9: Who is responsible for coordinating the emergency traffic routes? During initial phases of work, between South Columbia and Pittsboro, emergency vehicles will have a difficult time navigating construction areas and everyday traffic.

Engineer Response to Bidder Question 9: Refer to General Note 11 on Sheet G2 for temporary road closure notification requirements to project stakeholders and authorities having jurisdiction, including emergency vehicles. The Engineer and OWASA will assist the Contractor in coordinating a meeting with project stakeholders and authorities having jurisdiction, including emergency services.

Bidder Question 10: Is it correct that only NCDOT streets require mill & overlay of areas outside of the affected T-Sections? In this case we are to mill & overlay 25' outside of these affected areas, only in NCDOT roads.

Engineer Response to Bidder Question 10: Mill and overlay is only required along roadways which are owned and maintained by NCDOT. Refer to Appendix B.3, Special Provision 17 of the NCDOT Encroachment Agreement for mill and overlay requirements. The extents of final mill and overlay will be determined on site by representative of NCDOT and the Engineer.

-END OF DOCUMENT-



ROY COOPER
Governor

DIONNE DELLI-GATTI
Secretary

JON RISGAARD
Acting Director

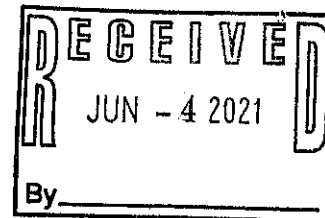

June 1, 2021

Mr. Todd Taylor, Executive Director
Orange Water & Sewer Authority
400 Jones Ferry Road
Carrboro, NC 27510

Subject: Plans and Specifications Funding
Approval
Orange Water & Sewer Authority
West Cameron Water Line Replacement,
Phase 2
Project No. WIF-1981.2

Dear Mr. Taylor:

The Division of Water Infrastructure (Division) has concluded its review of the project construction plans and specifications for the subject project. Based on this review, the Division has determined that the project is eligible for funding as follows:

Eligible

Installation of approximately 3,200 LF of 12-inch ductile iron water main, 500 LF of 2-inch PVC water main and associated appurtenances; abandonment via grout fill of approximately 6,600 LF of existing 12-inch cast iron and asbestos concrete water mains; removal and replacement of pavement, roadways, driveways and curbs; and sedimentation and erosion control devices.

Non Eligible

Paving of roadways in excess of the excavated area. Any installation of sewer service laterals outside the right-of-way. Spare parts, service contracts, maintenance contracts, and extended warranties. Change orders caused by subsurface conditions that could have been reasonably discovered as part of an investigation may not be eligible for funding.

Submit any addenda for the subject project plans and specifications no less than seven days before the bid opening.



North Carolina Department of Environmental Quality | Division of Water Infrastructure
512 N. Salisbury Street | 1633 Mail Service Center | Raleigh, North Carolina 27699-1633
919.707.9160

Mr. Todd Taylor, Executive Director

June 1, 2021

Page 3 of 3

If you have any questions, please contact Matthew B. Rushing, by phone at (919) 707-9060 or by email at matthew.rushing@ncdenr.gov.

Sincerely,

Kavitha Ambikadevi for

Vincent Jude Tomaino, PE, Supervisor
Drinking Water Projects Unit

Attachments: Approved Plans and Specifications
Project Bid Information Form

cc: Adam Paukovich, PE; McKim and Creed (Raleigh)
Vincent Jude Tomaino, PE (via email)
Mark Hubbard, PE (via email)
Matthew B. Rushing (via email)
SRF File (PS/PSAL)

PROJECT BID INFORMATION

<i>Applicant Name</i> _____	<i>DWI Project No.</i> _____
<i>Mailing Address</i> _____	

**** NOTE: Addenda:** All addenda must be submitted to your DWI / Drinking Water or Wastewater Technical Unit's project engineer for approval prior to opening bids. Changes to the scope of the project may result in funding being rescinded. **

Bid Information to be forwarded with the cost summary

- (a) Tabulations of all bids received (sealed by Engineer);
- (b) Copies of the bid(s) and bid bond the Applicant wishes to accept;
- (c) Resolution of tentative award from the Applicant's governing board;
- (d) Engineer's recommendation-of-award letter;
- (e) Proof of Bid Advertisement;
- (f) MBE/WBE (i.e., DBE) documents; (see MBE/WBE instructions);
- (g) American Iron-and-Steel Certification (only applicable for federally funded projects); AND
- (h) If budget/post-bid negotiations took place, submit all information associated with these negotiations.

These items and this form – once completed and signed/dated – must be submitted to your assigned DWI / Grant Management Unit project manager. If unclear to whom this submittal should be routed, please contact Mark Hubbard, GMU Supervisor.

Please note the following items must be submitted to DWI before any reimbursements will be made. All of the following items (see below) shall be submitted directly to Pam Whitley (pam.whitley@ncdenr.gov) of DWI:

- Capital Project Ordinance
- Site Certificate
- Closing Costs
- Executed Construction Contracts (*DWI will approve by letter*)
- A/E contracts (*DWI will approve by letter*)
- A/E Brooks Act Compliance Certification (*applicable to certain Federal projects*)
- Federal ID and DUNS numbers (*form was provided with the Loan Offer package*)
- LGC must receive the executed promissory note (PN) (*see guidance document for details re: when PN is generated*)

Mailing Address: Division of Water Infrastructure / 1633 Mail Service Center / Raleigh NC 27699-1633

****Complete the following two (2) below tables as appropriate to denote the subject project's proposed budget items (*project expenditures*) and its proposed revenue streams (*sources of funding*). The totalized amounts for "Revenue Sources..." and "Total Project Cost" shall be equivalent.****

REVENUE SOURCES FOR PROJECT CONSTRUCTION	
<i>List funds that are available for this project</i>	AMOUNT
DENR FUNDING (specify) ⇨	\$
LOCAL CASH	\$
GENERAL OBLIGATION or REVENUE BONDS	\$
OTHER AGENCY (specify) ⇨	\$
OTHER AGENCY (specify) ⇨	\$
OTHER (specify) ⇨	\$
OTHER (specify) ⇨	\$
TOTAL	\$

PROJECT COST SUMMARY (as-bid)		
Project Expenditures	TOTAL COST	DWI-ELIGIBLE COST*
Construction Contracts / Equipment Vendors & Suppliers		
Identify names of contractor(s) / vendor(s) / supplier(s) below, if any:		
6. CONTINGENCY (5% of Cons.Cnts./Equipment sub-total, max)		
Construction SUBTOTAL		
Professional Services: Technical		
Identify consulting engineer(s) / surveyor(s) / lab(s) etc. below, if any:		
Professional Services: Technical SUBTOTAL		
Professional Services: Non-Technical		
Identify attorney(s) / project manager(s) (e.g., COGs) / other(s) below, if any:		
Professional Services: Non-Technical SUBTOTAL		
Administrative Fee (i.e. Closing Costs) (Not eligible for SRF, Eligible for SRP)		
TOTAL	\$	\$

*Please see eligibility guidance for a full accounting of eligible costs.
 ** Please use the form provided on the website in addition to land cost invoices.

The Applicant's (i.e., Owner's) undersigned representative certifies below that the information above, and in any attached or enclosed statements and materials in support thereof, is true and correct to the best of his or her knowledge.

Signature of Authorized Representative *Name and Title (type or print)* *Date*

DOCUMENT 00 41 44 (ADDENDUM NO. 2)

PROPOSAL

(UNIT PRICE CONTRACT - BID FORM)

ARTICLE 1 – BID RECIPIENT

1.01 This Bid is submitted to:

EXECUTIVE DIRECTOR
ORANGE WATER AND SEWER AUTHORITY
400 JONES FERRY ROAD
CARRBORO, NORTH CAROLINA 27510
(919) 968-4421

Date: _____, 20_____

OWASA CIP: **#275-52**

Project: **WEST CAMERON AVENUE WATER MAIN REPLACEMENT – PHASE 2**

Name of Bidder: _____

Address of Bidder: _____

Phone Number of Bidder: _____

Contact Person for Bidder: _____

Phone Number of Contact: _____

Bidder's North Carolina General Contractor's License Number (required): _____

1.02 The undersigned Bidder proposes and agrees, if this Bid is accepted, to enter into an Agreement with Orange Water and Sewer Authority in the form included in the Bidding Documents to perform all Work as specified or indicated in the Bidding Documents for the prices and within the times indicated in this Bid and in accordance with the other terms and conditions of the Bidding Documents.

1.03 The undersigned Bidder hereby declares that the names of all persons interested in this Bid as principals appear in the blank spaces hereinafter provided for such purpose, that this Bid is in all respects fair and without collusion, that the Bidder has examined the locations of the proposed Work, the Advertisement for Bids, the Instructions to Bidders, Technical Specifications, M/WBE requirements of Orange Water and Sewer Authority, the Contract Documents and Bond forms, and the Drawings therein referred to and fully understands the same and agrees and accepts the terms and conditions thereof, that it is understood that

the estimated quantities are approximate only and are given for the purpose of comparing Bids upon a uniform basis, and that said estimate shall in no way affect the unit prices for the Work.

- 1.04 The undersigned Bidder hereby agrees to furnish at the Bidder's cost the expense of all the necessary labor, tools, apparatus, machinery, equipment, transportation, and all other things which may be required to fully and properly perform all the terms, covenants, provisions, and agreements of this Contract.
- 1.05 The undersigned Bidder hereby agrees to do said Work and furnish said materials as prescribed in the Contract Documents and Technical Specifications, and, according to the Drawings and requirements of the Engineer under said Contract Documents and Technical Specifications, in a first-class manner and to the best of the undersigned's ability at the following lump sum or unit prices.
- 1.06 The undersigned Bidder has examined the Site of the Work and all matters referred to in the Instructions to Bidders and the Contract Documents prepared by the Engineer for the Project, we, the undersigned Bidder, hereby offers to enter into a Contract to perform the Work for the lump sum or unit prices listed in this Bid Form in lawful money of the United States of America.
- 1.07 The undersigned Bidder acknowledges that it is the intent of these Contract Documents to obtain a Contract based on a **Unit Price Bid**, unless Lump Sum Prices are applied to the various portions of the Work and are specifically requested. In the event of errors in the arithmetical extension of unit prices to total prices, the unit price bid shall govern, and the Award of the Contract shall be based on the recomputed total prices. Where discrepancy exists between words and numerals, the written words shall govern. If a Bidder submits a Bid showing a unit price for a particular item and omits an extended total for that item, or a Bidder submits a Bid showing an extended total for a particular item and omits a unit price for that item, the omitted numbers shall be computed using the equation "Estimated Quantity x Unit Bid Price = Extended Total", so that the omission shall not render the Bid non-responsive or incomplete. If the Bidder leaves blank any lines or spaces indicated for the dollar amount of any item in the Bid, that omission will be understood and treated as if the Bidder had written in zero dollars (\$0.00) for that particular item in the Bid. Before applying the preceding two (2) sentences this paragraph, the following rule shall apply in the special case that it describes: In places where it is indicated that a Bid should show both words and numerals for a particular dollar amount, if the Bid shows the dollar amount in numerals but omits to show any dollar amount in words (or vice versa), the Bid shall be treated as if it had shown the indicated dollar amount in both numerals and words.
- 1.08 The undersigned Bidder shall be required to submit a complete detailed cost breakdown of Lump Sum Bid items for payment purposes, for approval by the Engineer, prior to the Award of the Contract.
- 1.09 The undersigned Bidder acknowledges that all costs for mobilization, demobilization, bonds, insurance, etc. shall be included in the Unit Price Bid indicated. There shall be no additional compensation for mobilization, demobilization, bonds, insurance, etc. and no adjustments to the Bid based on changes in the Scope of Work, including but not limited to, any additions to the Work on the Contract.

- 1.10 The undersigned Bidder acknowledges that the Project will be Awarded to the lowest responsible, responsive Bidder for the Project, as selected by Orange Water and Sewer Authority whose evaluation indicates that the Award will be in the best interest of the Project.
- 1.11 The undersigned Bidder acknowledges that all blanks on the Bid Form shall be completed by printing in ink or by typewriter and the Bid signed in ink. Erasures or alterations shall be initialed in ink by the person signing the Bid Form. A Bid Price shall be indicated for the Lump Sum or each Unit Price item listed therein, or the words, "No Bid", "No Change", or "Not Applicable" entered.
- 1.12 The undersigned Bidder acknowledges that the omission of prices for any item on the Bid Form, or the tendering of any unbalanced Bid may be the cause for the rejection of the submitted Bid.
- 1.13 The undersigned Bidder acknowledges that the payment will be made on the basis of the Work as actually executed at the Unit Prices or Lump Sum Prices set forth in the executed Contract and under the provisions of such Contract.
- 1.14 The undersigned Bidder acknowledges that there shall be no additional compensation to the Bidder for materials, equipment, or Work that is incidental to the successful completion of the Contract. Incidental costs include the costs inherent to the complete installation of those individual items included on the Bid Form.
- 1.15 The undersigned Bidder acknowledges that the Non-Collusive Affidavit for the Contractor shall be submitted with the Bid, and Non-Collusive Affidavit(s) for all Subcontractors (all tiers) for the apparent low Bidder shall be submitted within five (5) calendar days of the Bid Opening.
- 1.16 The undersigned Bidder acknowledges that it has included the Bid security as required by the Instructions to Bidders.
- 1.17 The undersigned Bidder agrees to comply with all requirements of local, State, or Federal permits that may be required for the completion of the Work.
- 1.18 The undersigned Bidder shall have all proper Contractor's licenses and privilege licenses required under State and local laws governing their respective trade(s).
- 1.19 The undersigned agrees that the rights of Orange Water and Sewer Authority and the recommendations of the Engineer are not to be questioned in the Award of a Contract.
- 1.20 The undersigned Bidder certifies compliance with the requirements of Article 2 of Chapter 64 of the North Carolina General Statutes ("E-Verify"), and represents that it will require any subcontractors to comply with the requirements of Article 2 of Chapter 64 of the General Statutes.
- 1.21 The undersigned Bidder certifies compliance with the requirements of Article 6 of Chapter 143 of the North Carolina General Statutes ("Iran Divestment") and that it is not listed on the State Treasurer's Final Divestment List found at the website address www.nctreasurer.com/Iran and updated every 180 days, and represents that it will require any subcontractors to comply with the requirements of Article 6 of Chapter 143 of the General Statutes.

ARTICLE 2 – BIDDER’S ACKNOWLEDGEMENTS

2.01 Bidder accepts all of the terms and conditions of the Instructions to Bidders, including without limitation those dealing with the disposition of Bid security. This Bid shall remain open and remain subject to acceptance, and is irrevocable, except as required by law, for ninety (90) calendar days from the Bid opening date, or for such longer period of time that Bidder may agree to in writing upon request of Orange Water and Sewer Authority.

2.02 If this Bid is accepted by Orange Water and Sewer Authority within the time period stated above, the Bidder will:

-Execute the Agreement within fifteen (15) calendar days of receipt of Notice of Award.

-Furnish the required Bonds within fifteen (15) calendar days of receipt of Notice of Award.

-Commence Work within ten (10) calendar days after written Notice to Proceed.

2.03 If this Bid is accepted by Orange Water and Sewer Authority within the time stated, and the Bidder fails to commence the Work or fails to provide the required bonds, the Bid security shall be forfeited as damages to Orange Water and Sewer Authority by reason of our failure, limited in amount to the lesser of the face value of the security deposit or the difference between this Bid and the Bid upon which a Contract is signed.

2.04 In the event Bid is not accepted by Orange Water and Sewer Authority within the time stated above, the required Bid security will be returned to the undersigned, in accordance with the provisions of the Instructions to Bidders; unless a mutually satisfactory arrangement is made for its retention and validity for an extended period of time.

ARTICLE 3 - BIDDER’S REPRESENTATIONS

3.01 In submitting this Bid, Bidder represents that:

A. Bidder has examined and carefully studied the Bidding Documents, and any data and reference items identified in the Bidding Documents, and hereby acknowledges receipt of the following Addenda:

Addendum No.:

Addendum Date:

B. Bidder has visited the Site, conducted a thorough, alert visual examination of the Site and adjacent areas, and become familiar with and satisfied itself as to the general, local, and Site conditions that may affect cost, progress, and performance of the Work.

- C. Bidder is familiar with and has satisfied itself as to all Laws and Regulations that may affect cost, progress, and performance of the Work.
- D. Bidder has carefully studied all: (1) reports of explorations and tests of subsurface conditions at or adjacent to the Site and all drawings of physical conditions relating to existing surface or subsurface structures at the Site that have been identified in the Supplementary Conditions, especially with respect to Technical Data in such reports and drawings, and (2) reports and drawings relating to Hazardous Environmental Conditions, if any, at or adjacent to the Site that have been identified in the Supplementary Conditions, especially with respect to Technical Data in such reports and drawings.
- E. Bidder has considered the information known to Bidder itself; information commonly known to contractors doing business in the locality of the Site; information and observations obtained from visits to the Site; the Bidding Documents; and any Site-related reports and drawings identified in the Bidding Documents, with respect to the effect of such information, observations, and documents on (1) the cost, progress, and performance of the Work; (2) the means, methods, techniques, sequences, and procedures of construction to be employed by Bidder; and (3) Bidder's safety precautions and programs.
- F. Bidder agrees, based on the information and observations referred to in the preceding paragraph, that no further examinations, investigations, explorations, tests, studies, or data are necessary for the determination of this Bid for performance of the Work at the bid price and within the times required, and in accordance with the other terms and conditions of the Bidding Documents.
- G. Bidder is aware of the general nature of work to be performed by Owner and others at the Site that relates to the Work as indicated in the Bidding Documents.
- H. Bidder has given Engineer written notice of all conflicts, errors, ambiguities, or discrepancies that Bidder has discovered in the Bidding Documents, and confirms that the written resolution thereof by Engineer is acceptable to Bidder.
- I. The Bidding Documents are generally sufficient to indicate and convey understanding of all terms and conditions for the performance and furnishing of the Work.
- J. The submission of this Bid constitutes an incontrovertible representation by Bidder that Bidder has complied with every requirement of this Article, and that without exception the Bid and all prices in the Bid are premised upon performing and furnishing the Work required by the Bidding Documents.

ARTICLE 4 - BIDDER'S CERTIFICATION

4.01 Bidder certifies that:

- A. This Bid is genuine and not made in the interest of or on behalf of any undisclosed individual or entity and is not submitted in conformity with any collusive agreement or rules of any group, association, organization, or corporation;
- B. Bidder has not directly or indirectly induced or solicited any other Bidder to submit a false or sham Bid;
- C. Bidder has not solicited or induced any individual or entity to refrain from bidding; and

D. Bidder has not engaged in corrupt, fraudulent, collusive, or coercive practices in competing for the Contract. For the purposes of this Paragraph 4.01.D:

“corrupt practice” means the offering, giving, receiving, or soliciting of anything of value likely to influence the action of a public official in the bidding process;

“fraudulent practice” means an intentional misrepresentation of facts made (a) to influence the bidding process to the detriment of Orange Water and Sewer Authority, (b) to establish bid prices at artificial non-competitive levels, or (c) to deprive Orange Water and Sewer Authority of the benefits of free and open competition;

“collusive practice” means a scheme or arrangement between two or more Bidders, with or without the knowledge of Orange Water and Sewer Authority, a purpose of which is to establish bid prices at artificial, non-competitive levels; and

“coercive practice” means harming or threatening to harm, directly or indirectly, persons or their property to influence their participation in the bidding process or affect the execution of the Contract.

ARTICLE 5 – BASIS OF BID (UNIT PRICE BID)

5.01 CIP: **#275-52**

Project: **WEST CAMERON AVENUE WATER MAIN REPLACEMENT – PHASE 2**

Project Description:

Complete and operable installation of approximately 3,200 linear feet of 12-inch restrained joint ductile iron water pipeline from a point roughly 150 feet north of the intersection of Merritt Mill Road and West Cameron Avenue to a point roughly 150 feet east of the intersection of Pittsboro Street and West Cameron Avenue.

Installation of approximately 200 linear feet of 24-inch steel casing to be installed via open cut under existing railroad lines in two (2) locations, through which the aforementioned 12-inch restrained joint ductile iron water pipeline will run.

As part of an alternate bid, installation of approximately 500 linear feet of 2-inch copper and PVC water pipeline on Cameron Court.

Installation of all temporary and permanent water services, interconnections, and fire hydrant assemblies required to install a complete and operable water lines meeting local requirements and requirements as described in the contract documents.

Abandonment of approximately 6,600 linear feet of 12-inch AC or CI pipeline by cellular concrete or grout fill.

As part of an alternate bid, abandonment of approximately 500 linear feet of 2-inch galvanized pipeline.

Applicable traffic control, restoration, erosion and sediment control, permitting, and other items required to meet local requirements and requirements as described in the contract documents.

The major work items included in the Base Bid, as described in the Specifications and as shown on the Drawings, are as follows:

Install approximately 3,200 linear feet of 12-inch water main and, as part of an alternate bid, approximately 500 linear feet of 2-inch water main. Install associated valves, fittings, services, interconnections, and fire hydrant assemblies, including open cut installation of pipeline in a 24-inch casing pipe under railroad tracks in two (2) locations. Cut and abandon by cellular concrete or grout fill, approximately 6,600 linear feet of existing 12-inch cast iron and 12-inch asbestos concrete water mains that are no longer in use.

The foregoing description shall not be construed as a complete description of all Work required.

The Unit Price Bid shall reflect all costs associated with furnishing and installing, and placing into service all items of Work as indicated on the Drawings and in the Technical Specifications, complete, in place, operable and accepted by Orange Water and Sewer Authority, per the Engineer's Contract Documents.

5.02 Not Used

5.03 Bidder shall complete the Work in accordance with the Contract Documents for the following TOTAL UNIT PRICE BID:

REMAINDER OF PAGE LEFT BLANK INTENTIONALLY

BID FORM

NOTE TO BIDDERS: DO NOT REMOVE THIS BID FORM FROM THE CONTRACT DOCUMENTS

UNIT PRICE BID CONTRACT

BASE BID

Item	Description	Estimated Quantity		Bid Unit Price		Total Bid Price
SECTION A - BASE BID, WEST CAMERON AVENUE						
1	Mobilization and Demobilization	1	LS	\$	/LS	\$
2	Ductile Iron Water Main, Class 350 Restrained Joint					
a	12" Diameter	3,000	LF	\$	/LF	\$
b	8" Diameter	390	LF	\$	/LF	\$
c	6" Diameter	250	LF	\$	/LF	\$
d	4" Diameter	125	LF	\$	/LF	\$
3	Type K Hard Copper Water Main, 2" Diameter	50	LF	\$	/LF	\$
4	24" Diameter Steel Encasement Pipe (min. 0.625" wall thickness) Installed by Open Cut with 12" Diameter Ductile Iron, Class 350 Restrained Joint Carrier Pipe	200	LF	\$	/LF	\$
5	Testing, Seeding and Restoration for Water Mains					
a	12" Diameter	3,200	LF	\$	/LF	\$
b	8" Diameter	390	LF	\$	/LF	\$
c	6" Diameter	250	LF	\$	/LF	\$
d	4" Diameter	125	LF	\$	/LF	\$
e	2" Diameter	50	LF	\$	/LF	\$
6	Ductile Iron Restrained Mechanical Joint Fittings Installed On and/or Connected to Existing Water Mains	2,650	LBS	\$	/LBS	\$
7	Ductile Iron Restrained Mechanical Joint Fittings Installed On New Water Mains	9,440	LBS	\$	/LBS	\$
8	Gate Valve with Box					
a	12" Diameter	35	EA	\$	/EA	\$
b	8" Diameter	16	EA	\$	/EA	\$
c	6" Diameter	7	EA	\$	/EA	\$
d	4" Diameter	4	EA	\$	/EA	\$
e	2" Diameter (including tap, saddle and brass nipple)	2	EA	\$	/EA	\$
f	16" Insertion Valve on Existing Water Main	1	EA	\$	/EA	\$

Item	Description	Estimated Quantity		Bid Unit Price		Total Bid Price
g	12" Insertion Valve on Existing Water Main w/ Concrete Restraint Assembly	1	EA	\$	/EA	\$
9	Fire Hydrant Assembly	5	EA	\$	/EA	\$
10	Remove Existing Fire Hydrant Assembly	5	EA	\$	/EA	\$
11	2" Permanent Blow Off Assembly	8	EA	\$	/EA	\$
12	4" Permanent Blow Off Assembly	3	EA	\$	/EA	\$
13	New 4" Water Service w/ 2" Meter and Meter Vault including Tee, Valve, Pipe, Fittings, Meter Setter and Meter Vault (complete)					
a	Same Side as Main (Open-Cut)	1	EA	\$	/EA	\$
b	Opposite Side From Main (Open-Cut)	1	EA	\$	/EA	\$
14	New 2" Water Service including Tap, Valve, Pipe, Fittings, Meter Setter and Meter Vault (complete)					
a	Same Side as Main (Open-Cut)	3	EA	\$	/EA	\$
15	New 3/4" or 1" Water Service including Tap, Corporation Stop, Pipe, Meter Setter and Meter Box (complete)					
a	Same Side as Main (Open-Cut)	24	EA	\$	/EA	\$
b	Opposite Side From Main (Trenchless)	16	EA	\$	/EA	\$
16	New 1" Dual Water Service, with 3/4" Meter Setters and Meter Boxes including Tap, Corporation Stop, Pipe and Fittings (complete)					
a	Same Side as Main (Open Cut)	2	EA	\$	/EA	\$
17	Temporary Water Service Connections and Interconnections (complete)					
a	3/4" or 1" Temporary Service	18	EA	\$	/EA	\$
b	2" Temporary Service or Interconnection	3	EA	\$	/EA	\$
c	4" Temporary Service or Interconnection	4	EA	\$	/EA	\$
d	6" Temporary Service or Interconnection	1	EA	\$	/EA	\$
e	Temporary Fire Hydrant Assembly Connection	2	EA	\$	/EA	\$
18	Abandon Existing Waterline by Grout Fill					
a	12" Diameter	6,600	LF	\$	/LF	\$
b	8" Diameter	330	LF	\$	/LF	\$
c	6" Diameter	120	LF	\$	/LF	\$

Item	Description	Estimated Quantity		Bid Unit Price		Total Bid Price
d	4" Diameter	120	LF	\$	/LF	\$
19	Cut and Cap Existing Waterline					
a	12" Diameter	17	EA	\$	/EA	\$
b	8" Diameter	16	EA	\$	/EA	\$
c	6" Diameter	5	EA	\$	/EA	\$
d	4" Diameter	9	EA	\$	/EA	\$
e	2" Diameter	3	EA	\$	/EA	\$
20	Abandon Existing Valve Box In-Place	65	EA	\$	/EA	\$
21	Abandon Existing Water Manhole In-Place	7	EA	\$	/EA	\$
22	Remove and Replace NCDOT Asphalt Roadway / Trench Repair (11" B25.0C + 2" S9.5C)	550	SY	\$	/SY	\$
23	Remove and Replace Town of Chapel Hill Asphalt Roadway/Trench Repair (10" CABC+5" B25.0B + 1.5" SF9.5A)	2,200	SY	\$	/SY	\$
24	Remove and Replace Town of Carrboro Asphalt Roadway/Trench Repair (8" CABC+2" SF9.5A)	50	SY	\$	/SY	\$
25	Remove and Replace Traffic Signal Loops	2,600	LF	\$	/LF	\$
26	Mill Existing Asphalt and Overlay with 1.5" Surface Course Asphalt	2,300	SY	\$	/SY	\$
27	Remove and Replace Concrete Sidewalk	80	SY	\$	/SY	\$
28	Remove and Replace Brick Sidewalk	130	SY	\$	/SY	\$
29	Remove and Replace Concrete Curb & Gutter	400	LF	\$	/LF	\$
30	Remove and Replace ADA Accessible Sidewalk Ramp	1	EA	\$	/EA	\$
31	Remove and Replace Railroad at Two Open Cut Crossings	1	LS	\$	/LS	\$
32	Rock Removal and Replacement with Select Backfill	125	CY	\$	/CY	\$
33	Undercut Excavation and Disposal of Unsuitable Material	275	CY	\$	/CY	\$
34	Separation/Protection Concrete	40	CY	\$	/CY	\$
35	Construction Fencing	100	LF	\$	/LF	\$
36	Tree Protection Fencing	100	LF	\$	/LF	\$
37	Standard Silt Fence	500	LF	\$	/LF	\$
38	Inlet Protection Devices	17	EA	\$	/EA	\$
39	Traffic and Pedestrian Control	1	LS	\$	/LS	\$

Item	Description	Estimated Quantity		Bid Unit Price		Total Bid Price
40	Allowances					
a	TOCH Engineering Fee Allowance	1	LS	\$ 7,500.00	/LS	\$ 7,500.00
b	NCDOT Bond Allowance	1	LS	\$ 1,500.00	/LS	\$ 1,500.00
c	Contingency Allowance	1	LS	\$ 25,000.00	/LS	\$ 25,000.00
TOTAL SECTION A - BASE BID (BID ITEMS 1 THRU 40)						\$

ALTERNATE BID

Item	Description	Estimated Quantity		Bid Unit Price		Total Bid Price
SECTION B - ADD ALTERNATE NO. 1, CAMERON COURT						
1	SDR-21 PVC Water Main, 2" Diameter	490	LF	\$	/LF	\$
2	2" Permanent Blow Off Assembly	1	EA	\$	/EA	\$
3	Testing, Seeding and Restoration for Water Mains					
a	2" Diameter	490	LF	\$	/LF	\$
4	New 3/4" or 1" Water Service including Tap, Corporation Stop, Pipe, Meter Setter and Meter Box (complete)					
a	Same Side as Main (Open-Cut)	7	EA	\$	/EA	\$
b	Opposite Side From Main (Trenchless)	3	EA	\$	/EA	\$
5	New 1" Dual Water Service, with 3/4" Meter Setters and Meter Boxes including Tap, Corporation Stop, Pipe and Fittings (complete)					
a	Opposite Side From Main (Trenchless)	1	EA	\$	/EA	\$
6	Abandon Existing 2" Waterline	1	LS	\$	/LS	\$
7	Remove and Replace Town of Chapel Hill Asphalt Roadway/Trench Repair (10" CABC+5" B25.0B + 1.5" SF9.5A)	100	SY	\$	/SY	\$
8	Rock Removal and Replacement with Select Backfill	25	CY	\$	/CY	\$
9	Undercut Excavation and Disposal of Unsuitable Material	25	CY	\$	/CY	\$
10	Traffic and Pedestrian Control	1	LS	\$	/LS	\$
TOTAL SECTION B - ADD ALTERNATE NO. 1 (BID ITEMS 1 THRU 10)						\$
TOTAL BID PRICE, SECTION A+B						\$

Bidder acknowledges that, (1) each Bid Unit Price includes an amount considered by Bidder to be adequate to cover Contractor's overhead and profit for each separately identified item, and (2) estimated quantities are not guaranteed, and are solely for the purpose of comparison of Bids, and final payment for all Unit Price Bid items shall be based on actual quantities, determined as provided in the Contract Documents.

TOTAL UNIT PRICE BID for the Project described in Sub-Article 5.01, complete as indicated by the Contract Documents (in words and numerals), for **SECTION A**:

_____ Dollars
and _____ Cents (\$ _____)

TOTAL UNIT PRICE BID for the Project described in Sub-Article 5.01, complete as indicated by the Contract Documents (in words and numerals), for **SECTION A+B**:

_____ Dollars
and _____ Cents (\$ _____)

Bidder _____
(Print Name)

Bidder _____
(Signature)

REMAINDER OF PAGE LEFT BLANK INTENTIONALLY

**CERTIFIED LIST OF EQUIPMENT/MATERIAL
MANUFACTURERS AND SUBCONTRACTORS**

The Bidder, _____, as part of the procedure for the submission of Bids on this Project, submits the following list of Equipment/Material Manufacturers and Subcontractors to be used in the performance of Work to be done on said Project. The list of Manufacturers and all equipment/materials furnished and Subcontractors shall be based on requirements of the Contract Documents. Changes to this list after the Bid opening shall only be as approved by Orange Water and Sewer Authority upon request by the Contractor or as required by Orange Water and Sewer Authority based upon review of Contractor's submittals:

EQUIPMENT/MATERIALS	MANUFACTURER
Ductile Iron Pipe	
Steel Casing Pipe	
Resilient Wedge Gate Valves	
Insertion Style Gate Valves	
Mechanical Joint Fittings	

WORK TASK	SUBCONTRACTOR
Railway Reconstruction	
NCDOT Traffic Loop Reconstruction	
Town of Chapel Hill Traffic Loop Reconstruction	

TEMPORARY WATER SERVICE CONNECTIONS:

Indicate Self Perform or Subcontract (write-in): _____

(NOTE: If Subcontract, indicated Subcontractor in previous Subcontractor section)

Indicate Installation of Temporary Main or Connection to Existing Main or Both (write-in): _____

(NOTE: If Temporary Main, indicate material type in previous Equipment/Materials section)

It is understood and agreed that, if awarded a Contract, the Contractor will not make any additions, deletions or substitutions to this certified list without the written consent of Orange Water and Sewer Authority.

CERTIFICATION AFFIDAVIT

THE ABOVE INFORMATION IS TRUE AND COMPLETE TO THE BEST OF MY KNOWLEDGE AND BELIEF. I FURTHER UNDERSTAND AND AGREE THAT, IF AWARDED A CONTRACT, THIS CERTIFICATION SHALL BE ATTACHED THERETO AND BECOME A PART THEREOF.

NAME OF SIGNER: _____
(Please Print or Type)

TITLE OF SIGNER: _____
(Please Print or Type)

DATE: _____ SIGNATURE: _____

-END OF CERTIFICATION-

REMAINDER OF PAGE LEFT BLANK INTENTIONALLY

ARTICLE 6 – TIME OF COMPLETION

6.01 Bidder agrees that the Work will be Substantially Complete within **365 CONSECUTIVE CALENDAR DAYS**, after the date when the Contract Time commences to run as provided in Paragraph 16.03 of the General Conditions and will be completed and ready for final payment in accordance with Paragraph 16.06 of the General Conditions within **395 CONSECUTIVE CALENDAR DAYS**, of the date when the Contract Time commences to run. In the event the Owner elects to award the add alternate bid item, the contract times listed herein will be increased by **45 CALENDAR DAYS**.

6.02 Not Used

6.03 Bidder accepts the provisions of the Agreement as to Liquidated Damages.

ARTICLE 7 - ATTACHMENTS TO THIS BID

7.01 The following documents are submitted with and made a condition of this Bid:

- A. Required Bid Security;
- B. List of Proposed Subcontractors;
- C. Qualification Statement for the Proposed Subcontractor for Railway Reconstruction and Restoration
- D. List of Proposed Suppliers;
- E. List of Project References;
- F. Evidence of authority to do business in the State of North Carolina; or a written covenant to obtain such license within the time for acceptance of Bids;
- G. Required Bidder Qualification Statement with supporting data;
- H. North Carolina Department of Environment Quality – Division of Water Infrastructure MBE/WBE Compliance Forms – Good Faith Efforts Form and Table A

ARTICLE 8 – BID CERTIFICATION

8.01 THE ABOVE INFORMATION IS TRUE AND COMPLETE TO THE BEST OF MY KNOWLEDGE AND BELIEF. I FURTHER UNDERSTAND AND AGREE THAT, IF AWARDED A CONTRACT, THIS CERTIFICATION SHALL BE ATTACHED THERETO AND BECOME A PART THEREOF.

SIGNATURE: _____

DATE: _____

8.02 We agree to diligently perform the Work in accordance with all Contract Documents, to complete such Work within the period as outlined in the Contract, and to begin Work within ten (10) consecutive calendar days after receipt of the Notice to Proceed from Orange Water and Sewer Authority.

ARTICLE 9 - CONTRACTOR EXPERIENCE

9.01 Not Used

9.02 Not Used

9.03 Not Used

ARTICLE 10 - BID FORM SIGNATURES

10.01 Refer to Document 00 21 15 – Instructions to Bidders for specific Bid Form signature requirements for corporations, partnerships, limited liability companies, individuals, or sole proprietorships.

ARTICLE 11 - QUALIFICATIONS OF SUBCONTRACTORS

11.01 Subcontractor for Railway Reconstruction and Restoration

- A. Provide written qualification statement from proposed subcontractor proposed to provide services for reconstruction and restoration of the open cut railway. The written qualification statement from the proposed subcontractor must state the subcontractor meets the following minimum requirements:
 - a. All subcontractor employees to have attended and be able to provide documentation of completion of Norfolk Southern Roadway Worker Protection Training for Railroad Workers
 - b. All subcontractor employees to have active CCS Safetsite card
 - c. Subcontractor to have active North Carolina General Contractor's license with Classification S (Railroad Construction) with a limitation suitable for the value of the railway work associated with the project
 - d. Subcontractor to provide Contractual Liability – Railroads endorsement to their commercial general liability policy, evidencing coverage is provided for work within 50 feet of a railroad.
 - e. Documentation supporting and/or proving items a thru d above is not required to be submitted with the Bid, but may be requested by the Owner in accordance with Article 12 of the Instructions to Bidders and Article 8.06 of the General Conditions.
- B. In addition, the written qualification statement for the proposed railway subcontractor shall include a listing of at least three (3) railway reconstruction projects completed within the past five (5) years, to include project name, location, completion date, brief description of the work, railway owner and professional reference(s).

ARTICLE 12 – SEQUENCE OF WORK

12.01 Not Used

12.02 Not Used

12.03 Not Used

12.04 Not Used

12.05 Not Used

12.06 Not Used

ARTICLE 13 - INTERIM COMPLETION DATES

13.01 Not Used

CORPORATION

The Corporate Seal of

(Bidder - print the full legal corporate name of firm)

(President/Vice President/Authorized Corporate Officer)

(Seal)

was hereunto affixed in the presence of:

(Secretary/Assistant Secretary)

(Seal)

Corporate Address:

(State of Incorporation)

LIMITED LIABILITY COMPANY

(Bidder - print the full legal name of firm)

(Authorized Firm Member)

(Seal)

was hereunto affixed in the presence of:

(Witness)

(Seal)

Firm Address:

(State of Formation)

INDIVIDUAL OR SOLE PROPRIETORSHIP

(Bidder - print the full name of individual or sole proprietorship)

(Seal)

Individual or Sole Proprietorship Address:

PARTNERSHIP

(Bidder - print the full legal corporate name of partnership)

_____ (Partner and Title) (Seal)	_____ (Partner and Title) (Seal)
_____ (Partner and Title) (Seal)	_____ (Partner and Title) (Seal)
_____ (Partner and Title) (Seal)	_____ (Partner and Title) (Seal)
_____ (Partner and Title) (Seal)	_____ (Partner and Title) (Seal)
_____ (Partner and Title) (Seal)	_____ (Partner and Title) (Seal)

(All Partners shall sign, additional signatures with titles and seals may be added below.)
was hereunto affixed in the presence of:

(Witness)

(Seal)

Partnership Address:

JOINT VENTURE

If the Bid is a joint venture, add additional forms of execution for each member of the joint venture in the appropriate manner using the forms from above.

BID BOND

This is a Bid Bond that is subject to the provisions of G.S. 143-129 (b) of the North Carolina General statutes.

This Bond is executed on _____, 20____

The name of the Principal is _____
(Correct name of Contractor)

(A Corporation, a Partnership, or an Individual, as the case may be)

The name of the Surety is _____

Orange Water and Sewer Authority is the Owner.

The amount of the Bond is _____
_____ (Dollars) \$_____

KNOW BY ALL MEN BY THESE PRESENTS, the Principal and Surety above named are hereby held and firmly bound unto the above named Owner hereinafter called the Owner in the penal sum of the amount stated above in lawful money of the United States, for the payment of which, well and truly to be made, we hereby jointly and severally bind ourselves, our heirs, executors, administrators, successors, and assigns.

The condition of the above obligation is such that whereas the Principal has submitted to the Owner a certain Bid attached hereto and hereby made a part hereof to enter into a Contract in writing, for the construction of:

WEST CAMERON AVENUE WATER MAIN REPLACEMENT – PHASE 2

NOW, THEREFORE

- (a) If said Bid shall be rejected, or in the alternate,
- (b) If said Bid shall be accepted and the Principal shall execute and deliver a Contract in the Form of Contract attached hereto (properly completed in accordance with said Bid) and shall furnish a bond for its faithful performance of said Contract, and for the payment of all persons performing labor or furnishing materials in connection therewith, and shall in all other respects perform the agreement created by the acceptance of said Bid;
- (c) Then this obligation shall be void, otherwise the same shall remain in force and effect; it being expressly understood and agreed that the liability of the Surety for any and all claims hereunder shall, in no event, exceed the penal amount of this obligation as herein stated.

BID BOND (CONTINUED)

The Surety, for value received, hereby stipulates and agrees that the obligations of said Surety and its Bond shall be in no way impaired or affected by any extension of the time within which the Owner may accept such Bid; and said Surety does hereby waive notice of any such extension.

IN WITNESS WHEREOF, the Principal and the Surety have hereunto set their hands and seals, and such of them as are corporations have caused their corporate seals to be hereto affixed and these presents to be signed by their proper officers, the day and year first set forth above.

Execution by Principal:

(If Contractor is a Partnership, all partners should execute Bond below)

ATTEST:

Principal Secretary
(SEAL)

BY: _____
Principal

Principal

Principal

Witness as to Principal

(Address)

(Phone Number)

Execution by Surety:

ATTEST:

North Carolina Resident Agent
(SEAL)

Surety

(Address)

Witness as to Surety

(Phone Number)

POWER OF ATTORNEY

(Attach)

PROPOSAL SIGNATURE

Bidder operates under the legal name of _____

BIDDERS COMPLETE THE APPROPRIATE SECTION*

CORPORATION* The Bidder is a corporation, has a corporate seal and the full names of its officers are:

President _____

Secretary _____

Vice President _____

Treasurer _____

The _____ (officer's title) is authorized to sign construction proposals and contracts for the company by action of its Board of Directors taken on _____, 20____ a certified copy of which is attached. (Strike out previous sentence if not applicable. This section must be completed if President or Vice President is not the signatory party.)

PARTNERSHIP* The Bidder is a partnership consisting of individual partners whose full names are:

INDIVIDUAL* The Bidder is an individual whose full name is:

Print Name of Legal Entity

By: _____

Print name and title of signatory

CORPORATIONS ONLY – Secretary or Assistant Secretary attest and affix corporate Seal:

Circle one: Secretary or Assistant Secretary

State of Incorporation

Address and telephone number

Subscribe and sworn to me this _____ day of _____, 20____.

Notary Public _____ (Seal)

My Commission Expires: _____

CONTRACTOR'S AFFIDAVIT OF ORGANIZATION AND AUTHORITY

STATE OF _____

COUNTY OF _____

_____ being the first duly sworn on oath deposes and says that the Bidder on the attached Bid proposal is organized as indicated below and that all statements herein made are made on behalf of such Bidder and that this deponent is authorized to make them.

(Fill Out Applicable Paragraph)

1. CORPORATION:

The Bidder is a corporation organized and existing under the laws of the State of _____ and its President is _____;

its Secretary is _____,

and it does have a corporate seal. The _____ (officer's title) is authorized to sign construction Contracts and Bids for the company by action of its Board of Directors taken on _____, 20____, a certified copy of which is hereto attached. (Strike out last sentence if not applicable.)

2. PARTNERSHIP:

The Bidder is a partnership consisting of _____ and _____, partners doing business under the name of _____.

3. INDIVIDUAL / SOLE TRADER:

The Bidder is an individual and if operating under a trade name, such trade name is as follows:

4. ADDRESS:

The business address of the Bidder is as follows: _____

Its phone number is _____.

Bidder

By: _____

Subscribed and sworn to before me this _____ day of _____, 20____

My commission expires: _____

Notary Public

(SEAL)

NON-COLLUSION AFFIDAVIT FOR CONTRACTOR'S

STATE OF _____

COUNTY OF _____

_____ being first duly sworn,
deposes and says that:

- (1) He/She is the: _____
Owner, Partner, President, Vice President or other officer with evidence of authority attached
of _____
the Bidder that has submitted the attached BID;
- (2) He/She is fully informed respecting the preparation and contents of the attached Bid and of all pertinent circumstances respecting such Bid;
- (3) Such BID is genuine and is not a collusive or sham Bid;
- (4) Neither the said Bidder nor any of its officers, partners, owners, agents, representatives, employees, or parties in interest, including this affiant, have in any way colluded, conspired; connived, or agreed, directly or indirectly, with any other Bidder, firm, or person to submit a collusive or sham Bid in connection with the Contract for which the attached Bid has been submitted; or to refrain from bidding in connection with such Contract; or have in any manner, directly or indirectly, sought by agreement or collusion, or communication, or conference with any Bidder, firm, or person to fix the price or prices in the attached Bid or of any other Bidder, or to fix any overhead, profit, or cost elements of the Bid price or the Bid price of any other Bidder, or to secure through any collusion, conspiracy, connivance, or unlawful agreement any advantage against (Recipient), or any person interested in the proposed Contract;
- (5) The price or prices quoted in the attached Bid are fair and proper and are not tainted by any collusion, conspiracy, connivance, or unlawful agreement on the part of the Bidder or any other of its agents, representatives, owners, employees, or parties in interest, including this affidavit.

BY: _____

ITS: _____
Title

CORPORATIONS ONLY

Secretary or Assistant, attest & affix corporate seal

Subscribed and sworn to before me this _____ day of _____, 20__

_____ My commission expires: _____

Notary Public

(SEAL)

NON-COLLUSION AFFIDAVIT FOR SUBCONTRACTOR(S)
(DUE WITHIN 5 CALENDAR DAYS OF THE BID OPENING)

STATE OF _____

COUNTY OF _____

_____ being first duly sworn,
deposes and says that:

- (1) He/She is _____ of _____, hereinafter referred to as the "Subcontractor";
- (2) He/She is fully informed respecting the preparation and contents of the Subcontractor's Proposal submitted by the Subcontractor to _____, the Contractor for certain work in connection with the _____ Contract pertaining to the Project in _____ (City or County, and State);
- (3) Such Subcontractor's Proposal is genuine and is not a collusive or sham proposal;
- (4) Neither the Subcontractor nor any of its officers, partners, owners, agents, representatives, employees, or parties in interest, including this affiant, has in any way colluded, conspired, connived, or agreed, directly or indirectly with any other Bidder, firm or person to submit a collusive or sham Proposal in connection with such Contract or to refrain from submitting a Proposal in connection with such Contract, or has in any manner, directly or indirectly, sought by unlawful agreement or connivance with any other Bidder, firm or person to fix the price or prices in said Contractor's Proposal, or to fix any overhead, profit, or cost elements of the price or prices in said Contractor's Proposal, or to secure through collusion, conspiracy, connivance, or unlawful agreement any advantage against the _____ (Local Public Agency) or any person interested in the proposed Contract; and
- (5) The price or prices quoted in the Subcontractor's Proposal are fair and proper and are not tainted by any collusion, conspiracy, connivance, or unlawful agreement on the part of the Bidder or any of its agents, representatives, owners, employees, or parties in interest, including this affiant.

(Signed) _____

Title

Subscribed and sworn to before me this _____ day of _____, 20__

_____ My commission expires: _____

Notary Public

(Seal)

EQUAL EMPLOYMENT OPPORTUNITY CERTIFICATION

During the performance of this Contract the Contractor agrees as follows:

- a. The Contractor will not discriminate against any employee or applicant because of race, color, religion, sex, or national origin. The Contractor will take affirmative action to ensure that applicants are employed, and that employees are treated during employment, without regard to race, color, religion, sex, or national origin. Such action shall include but not be limited to the following: employment, upgrading, demotion, or transfer, recruitment or recruitment advertising, layoff or termination, rates of pay or other forms of compensation, and selection for training, including apprenticeship. The Contractor agrees to post in conspicuous places, available to employees and applicants for employment, notices setting forth the provisions of the nondiscrimination clause.
- b. The Contractor will, in all solicitations or advertisements for employees placed by or on behalf of the Contractor, state that all qualified applicants will receive consideration for employment without regard to race, color, religion, sex, or national origin.
- c. The Contractor will send to each labor union or representative of workers with which he has a collective bargaining agreement or other Contract understanding, a notice; to be provided, advising the labor union or worker's representative of the Contractor's commitments under the Equal Employment Opportunity Section of this Contract, and shall post copies of the notice in conspicuous places available to employees and applicants for employment.
- d. In the event of the Contractor's noncompliance with the nondiscrimination clauses of this Contract or with any of such rules, regulations, or orders, this Contract may be canceled, terminated, or suspended in whole or in part and the Contractor may be declared ineligible for further Owner Contracts,
- e. The Contractor will include the provisions of this section in every subcontract or purchase order unless exempted by rules, regulations, or orders of the Owner so that such provisions will be binding upon each Subcontractor or vendor.

(Complete this section for signatures by a CORPORATION):

(CORPORATE SEAL)

Corporate Name

ATTEST:

Secretary* or Assistant Secretary*

BY:

President* or Vice President*

*choose one

(Complete this section for signatures by PARTNERSHIP and INDIVIDUAL):

WITNESS:

BY:

(Seal)

(ACKNOWLEDGEMENT OF THE ABOVE SIGNATURE MUST BE NOTARIZED USING THE FORM ON THE FOLLOWING PAGE)

**ACKNOWLEDGEMENT FOR
EQUAL EMPLOYMENT OPPORTUNITY CERTIFICATION**

Corporate Acknowledgement

(Use this portion of the form for acknowledgement of signature by a Corporation):

STATE OF _____

COUNTY OF _____

I, the undersigned notary public, do hereby certify that _____ personally appeared before me this day and acknowledged that he/she is *Secretary* or Assistant Secretary** of _____, a corporation, and that by authority duly given and as the act of the corporation, the foregoing instrument was signed in its name by its *President* or Vice President**, sealed with its corporate seal, and attested by himself as its *Secretary* or Assistant Secretary**.

**choose one*

WITNESS my hand and notarial seal this _____ day of _____, 20____

My commission expires _____.
(SEAL)

Notary Public

Individual or Partnership Acknowledgement

(Use this portion of the form for acknowledgement of signature by a partnership or an individual.)

NORTH CAROLINA

(Enter correct State and County if different than shown.)

_____ COUNTY

I, the undersigned Notary Public, do hereby certify that, _____ personally appeared before me this day and acknowledged the due execution of the foregoing instrument.

WITNESS my hand and notarial seal this _____ day of _____, 20____

My commission expires: _____.

Notary Public (SEAL)

MINORITY BUSINESS PARTICIPATION

Provide with the Bid:

Under G.S. 143-128.2(c) the undersigned Bidder shall identify on its Bid Proposal the minority businesses that it will use on the Project and the total dollar value of the bid that will be performed by the minority businesses and list the good faith efforts (**Affidavit A**) made to solicit participation. A Contractor that performs all of the Work with its own workforce may submit an **Affidavit B** to that effect in lieu of **Affidavit A** required above.

After the Bid opening:

Orange Water and Sewer Authority will consider all bids and alternates, and determine the lowest responsible, responsive Bidder. Upon notification of being the apparent low Bidder, the Bidder shall then file within 72 hours of the notification of being the apparent lowest Bidder, the following:

An **Affidavit C** that includes a description of the portion of Work to be executed by minority businesses, expressed as a percentage of the total Contract Price, which is equal to or more than the 10% goal established. This affidavit shall give rise to the presumption that the Bidder has made the required good faith effort; or **Affidavit D** of its good faith effort to meet the goal. The document must include evidence of all good faith efforts that were implemented, including any advertisements, solicitations, and other specific actions demonstrating recruitment and selection of minority businesses for participation in the contract.

These forms are included herein:

- (1) Identification of Minority Business Participation
- (2) Affidavit A – Listing of the Good Faith Effort
- (3) Affidavit B – Intent to Perform Contract with Own Workforce
- (4) Affidavit C – Portion of Work to be Performed by Minority Firms
- (5) Affidavit D – Good Faith Efforts

Identification of Minority Business Participation

I, _____,
(Name of Bidder)

do hereby certify that on this Project, we will use the following minority business enterprises as construction subcontractors, vendors, suppliers or providers of professional services.

Firm Name, Address and Phone #
Category

Work type

*Minority

Firm Name, Address and Phone # Category	Work type	*Minority

*Minority categories: Black, African American (**B**); Hispanic (**H**); Asian American (**A**); American Indian (**I**); Female (**F**); Socially and Economically Disadvantaged (**D**)

The total value of minority business contracting will be (\$)_____

State of North Carolina AFFIDAVIT A – Listing of the Good Faith Efforts

County of _____

Affidavit of _____ (Name of Bidder)

I have made a good faith effort to comply under the following areas checked:

Bidders must earn at least 50 points from the good faith efforts listed for their bid to be considered responsive (North Carolina Administrative Code 01 NCAC 30I .0102)

- 1 – (10 pts)** Contacting minority businesses that reasonably could have been expected to submit a quote and that were known to the contractor or available on State or local government maintained lists at least 10 days before the bid or proposal date and notifying them of the nature and scope of the work to be performed.
- 2 – (10 pts)** Making the construction plans, specifications, and requirements available for review by prospective minority businesses, or providing these documents to them at least 10 days before the bid or proposals are due.
- 3 – (15 pts)** Breaking down or combining elements of work into economically feasible units to facilitate minority participation.
- 4 – (10 pts)** Working with minority trade, community, or contractor organizations identified by the Office for Historically Underutilized Businesses and included in the bid documents that provide assistance in recruitment of minority businesses.
- 5 – (10 pts)** Attending any pre-bid meetings scheduled by the public owner.
- 6 – (20 pts)** Providing assistance in getting required bonding or insurance or providing alternatives to bonding or insurance for subcontractors.
- 7 – (15 pts)** Negotiating in good faith with interested minority businesses and not rejecting them as unqualified without sound reasons based on their capabilities. Any rejection of a minority business based on lack of qualification should have the reasons documented in writing.
- 8 – (25 pts)** Providing assistance to an otherwise qualified minority business in need of equipment, loan capital, lines of credit, or joint pay agreements to secure loans, supplies, or letters of credit, including waiving credit that is ordinarily required. Assisting minority businesses in obtaining the same unit pricing with the bidder's suppliers in order to help minority businesses in establishing credit.
- 9 – (20 pts)** Negotiating joint venture and partnership arrangements with minority businesses in order to increase opportunities for minority business participation on a public construction or repair project when possible.
- 10 – (20 pts)** Providing quick pay agreements and policies to enable minority contractors and suppliers to meet cash-flow demands.

The undersigned, if apparent low bidder, will enter into a formal agreement with the firms listed in the Identification of Minority Business Participation schedule conditional upon scope of contract to be executed with the OWNER. Substitution of contractors must be in accordance with G.S. 143-128.2(d). Failure to abide by this statutory provision will constitute a breach of the Contract.

The undersigned hereby certifies that he or she has read the terms of the minority business commitment and is authorized to bind the BIDDER to the commitment herein set forth.

Date: _____ Name of Authorized Officer: _____

Signature: _____

Title: _____

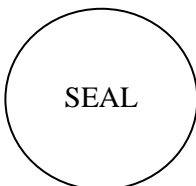

State of North Carolina, County of _____

Subscribed and sworn to before me this ____ day of _____ 20____

Notary Public _____ My commission expires _____

AFFIDAVIT B – Intent to Perform Contract with Own Workforce

County of _____

Affidavit of _____
(Name of Bidder)

I hereby certify that it is our intent to perform 100% of the work required for the _____

(Name of Project)

In making this certification, the Bidder states that the Bidder does not customarily subcontract elements of this type project, and normally performs and has the capability to perform and will perform all elements of the work on this project with his/her own current work forces; and

The Bidder agrees to provide any additional information or documentation requested by the Owner in support of the above statement.

The undersigned hereby certifies that he or she has read this certification and is authorized to bind the Bidder to the commitments herein contained.

Date: _____ Name of Authorized Officer: _____

Signature: _____

Title: _____

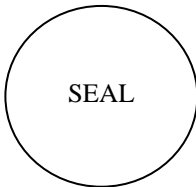

State of North Carolina, County of _____

Subscribed and sworn to before me this ____ day of _____ 20____

Notary Public _____

My commission expires _____

AFFIDAVIT C – Portion of the Work to be Performed by Minority Firms

County of _____

***** (NOTE: THIS FORM IS NOT TO BE SUBMITTED WITH THE BID PROPOSAL) *****

If the portion of the Work to be executed by minority businesses as defined in G.S. 143-128.2(g) is **equal to or greater than 10%** of the Bidder's Total Contract Price, then the Bidder must complete this affidavit. This affidavit shall be provided by the apparent lowest responsible, responsive Bidder within **72 hours** after notification of being low Bidder.

Affidavit of _____ I do hereby certify that on the
(Name of Bidder)

(Project Name)

Project ID# _____ Amount of Bid \$ _____

I will expend a minimum of _____% of the total dollar amount of the contract with minority business enterprises. Minority businesses will be employed as construction subcontractors, vendors, suppliers, or providers of professional services. Such work will be subcontracted to the following firms listed below.

Attach additional sheets if required

Name and Phone Number	*Minority Category	Work description	Dollar Value

*Minority categories: Black, African American (**B**); Hispanic (**H**); Asian American (**A**); American Indian (**I**); Female (**F**); Socially and Economically Disadvantaged (**D**)

Pursuant to G.S. 143-128.2(d), the undersigned will enter into a formal agreement with Minority Firms for work listed in this schedule conditional upon execution of a contract with the Owner. Failure to fulfill this commitment may constitute a breach of the Contract.

The undersigned hereby certifies that he or she has read the terms of this commitment and is authorized to bind the Bidder to the commitment herein set forth.

Date: _____ Name of Authorized Officer: _____

Signature: _____

Title: _____



State of North Carolina, County of _____

Subscribed and sworn to before me this ___ day of _____ 20____

Notary Public _____

My commission expires _____

AFFIDAVIT D – Good Faith Efforts

County of _____

***** (NOTE: THIS FORM IS NOT TO BE SUBMITTED WITH THE BID PROPOSAL) *****

If the goal of 10% participation by minority business **is not** achieved, the Bidder shall provide the following documentation to the Owner of his good faith efforts:

Affidavit of: _____
 (Name of Bidder)

I do certify the attached documentation as true and accurate representation of my good faith efforts.
 (Attach additional sheets if required)

Name and Phone Number	*Minority Category	Work description	Dollar Value

*Minority categories: Black, African American (**B**); Hispanic (**H**); Asian American (**A**); American, Indian (**I**); Female (**F**); Socially and Economically Disadvantaged (**D**)

Documentation of the Bidder's good faith efforts to meet the goals set forth in these provisions.

Examples of documentation include, but are not limited to, the following evidence:

- A. Copies of solicitations for quotes to at least three (3) minority business firms from the source list provided by the State for each subcontract to be let under this contract (if 3 or more firms are shown on the source list). Each solicitation shall contain a specific description of the work to be subcontracted, location where bid documents can be reviewed, representative of the Prime Bidder to contact, and location, date and time when quotes must be received.
- B. Copies of quotes or responses received from each firm responding to the solicitation.
- C. A telephone log of follow-up calls to each firm sent a solicitation.
- D. For subcontracts where a minority business firm is not considered the lowest responsible sub-bidder, copies of quotes received from all firms submitting quotes for that particular subcontract.
- E. Documentation of any contacts or correspondence to minority business, community, or contractor organizations in an attempt to meet the goal.
- F. Copy of pre-bid roster.
- G. Letter documenting efforts to provide assistance in obtaining required bonding or insurance for minority business.
- H. Letter detailing reasons for rejection of minority business due to lack of qualification.
- I. Letter documenting proposed assistance offered to minority business in need of equipment, loan capital, lines of credit, or joint pay agreements to secure loans, supplies, or letter of credit, including waiving credit that is ordinarily required.

AFFIDAVIT D – Good Faith Efforts (continued)

Failure to provide the documentation as listed in these provisions may result in rejection of the bid and award to the next lowest responsible and responsive Bidder.

Date: _____ Name of Authorized Officer: _____

Signature: _____

Title: _____

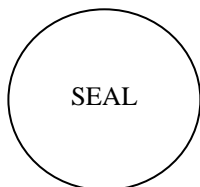

State of North Carolina, County of _____

Subscribed and sworn to before me this ___ day of _____ 20__

Notary Public _____

My commission expires _____

-END OF DOCUMENT-

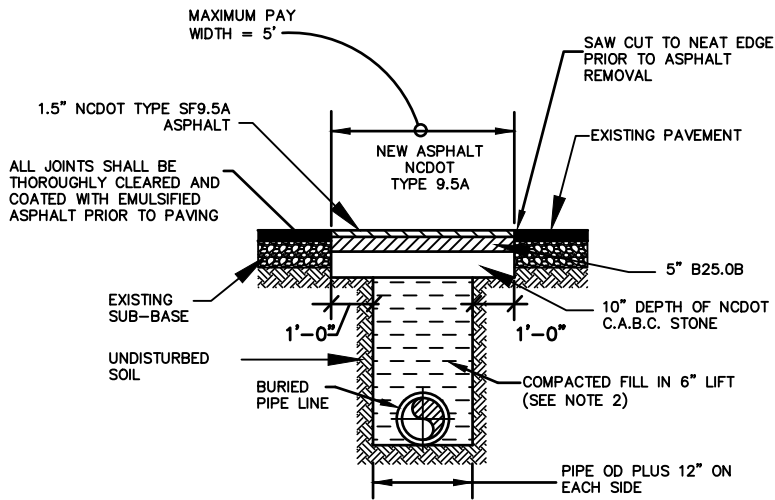

1. THE PAVEMENT CUT SHALL BE DEFINED BY A STRAIGHT EDGE PREFERABLY A MACHINE SAW CUT.
2. THE TRENCH SUBGRADE MATERIAL SHALL BE BACKFILLED WITH SUITABLE MATERIAL AND COMPACTED TO A DENSITY OF AT LEAST 95% OF THAT OBTAINED BY COMPACTING A SAMPLE OF THE MATERIAL IN ACCORDANCE WITH AASHTO T-99 AS MODIFIED IN NCDOT.
3. THE SAME DEPTH OF PAVEMENT MATERIAL WHICH EXISTS SHALL BE REINSTALLED, BUT IN NO CASE SHALL THE ASPHALT BE LESS THAN THE THICKNESS SHOWN ABOVE.
4. THE ASPHALT PAVEMENT MATERIAL SHALL BE INSTALLED AND COMPACTED THOROUGHLY TO ACHIEVE A SMOOTH LEVEL PATH.
5. IN AREAS WHERE THE ASPHALT REPAIR PATCH WILL BE MILLED AND OVERLAID WITHIN 60 DAYS, THE SURFACE COURSE MAY BE DELETED AND THE ENTIRE REQUIRED ASPHALT THICKNESS BE INSTALLED WITH THE SPECIFIED BASE COURSE.

MC-01 ASPHALT REPAIR (TOWN OF CHAPEL HILL ROADS)

N.T.S.



Venture IV Building, Suite 500
 1730 Varsity Drive
 Raleigh, North Carolina 27606-2689
 Phone: (919) 233-8091, Fax: (919) 233-8031
 NC License# F-1222
 www.mckimcreed.com

**WEST CAMERON AVENUE WATER LINE
 REPLACEMENT - PHASE 2**

MISCELLANEOUS DETAILS ADDENDUM #2

PROJ. START DATE:	2020 JAN
MCE PROJ. #	01519-0049
DRAWN	CEB
DESIGNED	JEB
CHECKED	KJS
PROJ. MGR.	KJS

ADD#2
DRAWING NUMBER
N/A
REVISION

STATUS: **ADDENDUM #2**